

REV 更改号	DATE 日期	REVISION DETAILS 更改内容	APPD 审核并批准

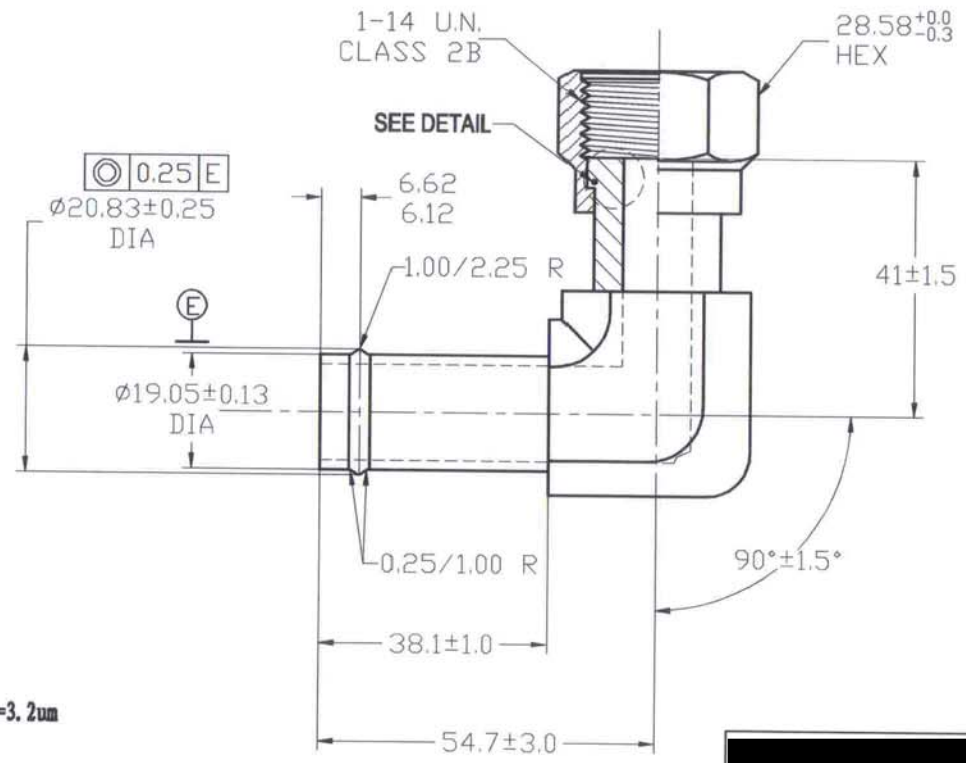
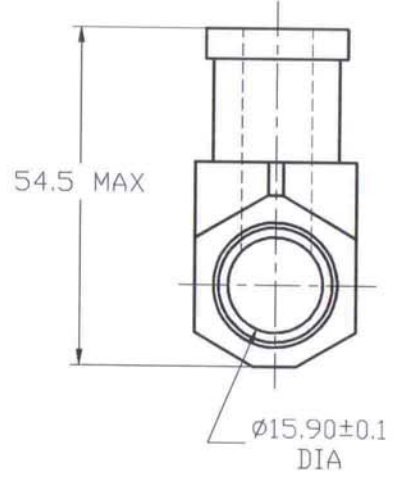
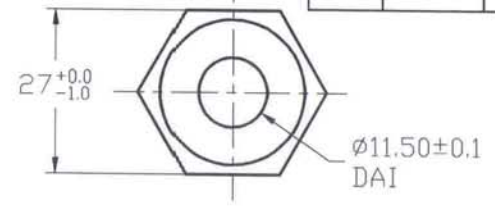
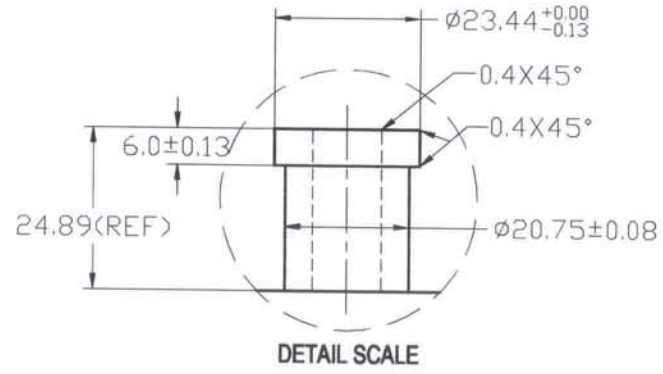

UNLESS SPECIFIED
ALL DIMENSIONS IN mm
MACHINED SURFACES Ra=3.2um
ANGLE TOLERANCES ±1°
Other tolerance exept angles,
in accordance with
GB/T1804-2000(ISO2768-1)-m
and GB/T1184-1996(ISO2768-2)-m

其它事项,
图示尺寸单位为mm
未注机加工表面粗糙度Ra=3.2um
角度公差 ±1°
其它未注公差 (除角度外) 均按:
GB/T1804-2000 (ISO2768-1)-m和
GB/T1184-1996 (ISO2768-2)-m

PART No 零件名		40976-12-10FSSW	
SCALE:	APPD: 批准 Zhangjian	DRN: 制图 TangHailing	2014.09.09
NTS	DATE: 日期 12/09/14	CHK: 审核 LIJunBiao	2014.09.09

MATERIAL	Chinese steel 45
FINISH	Remove all sharp edges,burns,slivers and swarf, break all edges 0.127-0.254mm. 去除所有毛刺, 铁屑等残留物, 锐边倒钝0.127-0.254mm. ZINC PLATED WITH TRIVALENT CHROMATE AND NO RED CORROSION IN 96 HOURS SALT SPRAY TEST. 镀锌, 三价铬钝化, 银白色, 96小时盐雾试验无红斑。